

Cim 702

"CIMFIRST" KULEVENTIL MED ELEKTRISK AKTUATOR - INNVENDIG GJENGE / INNVENDIG GJENGE - TYPE T10



Den er produsert av en messinglegering som er i henhold til standard EN 12165-CW617N-M.

Nominelt trykk: PN40

Arbeidstemperatur: -20 til 150°C

Åpne-/lukketid: 30 sekunder

MENGDE OG TRYKKTAP

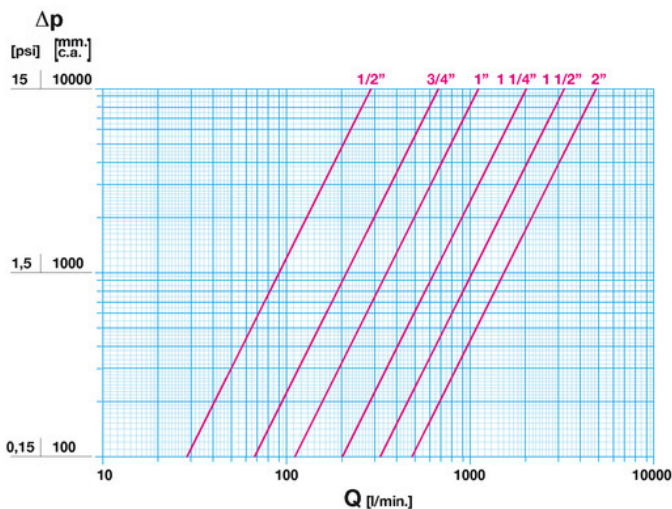

Noter:
 1 l/min = 0,06 m3/h
 1 m3/h = 16,67 l/min
 1 bar = 10.000 mm w.c.
 1 psi = 690 mm w.c.

TRYKK OG TEMPERATUR TABELL

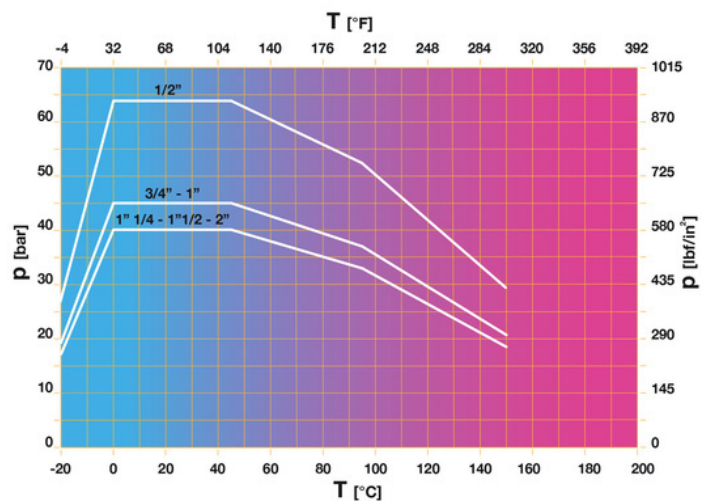

1 bar = 14,5 psi
 1 bar = 14,5 lbf/in2
 °C = 5/9 x (°F-32)
 °F = 32 + (9/5 x °C)

TEKNISK TEGNING

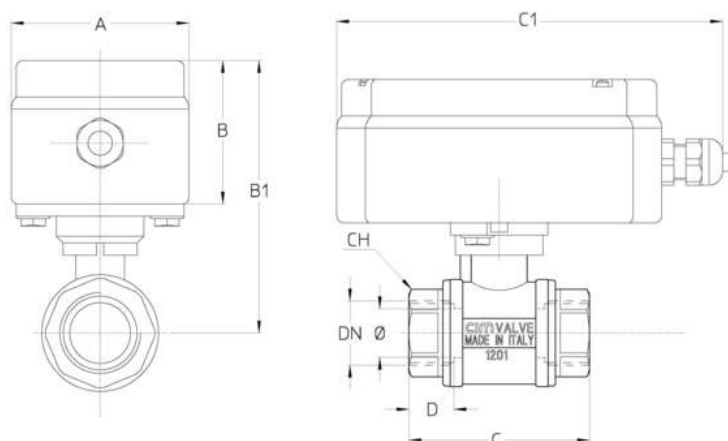

DN	1/2"	3/4"	1"	1"1/4	1"1/2	2
Φ mm	15	20	25	32	40	50
Grms.	840	1060	1300	2650	3000	4195
A	73	73	73	73	73	73
B	59,5	59,5	59,5	59,5	59,5	59,5
B1	103	112	115,5	173	179	185,5
C	64	74	88	100,5	106	130
C1	157	157	15	157	157	157
D	15	16	19	21	21	26
CH	27	32	41	49	55	70

TEKNISKE EGENSKAPER

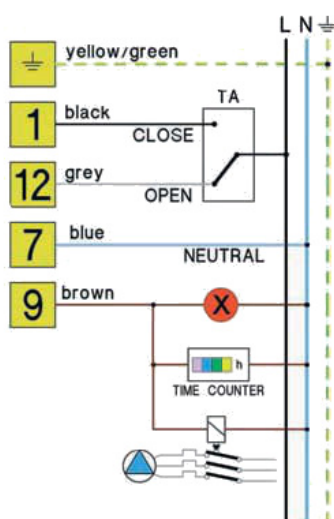

KV = Kapasitet i m³/t ved 1 bar trykktap
 CM = Arbeids torque i Nm
 CS = Start torque i Nm
 MT = Maximum torque på spindelen i Nm

	KV CM CS MT					
DN	1/2"	3/4"	1"	1"1/4	1"1/2	2"
Ø mm	15	20	25	32	40	50
KV	17	41	68	123	198	290
CM	1,5	3,5	3,5	3,5	4	4,5
CS	3	5,5	6	6	6	7
MT	20	45	45	93	93	93
DPmax	16	16	16	10	10	10

VÅRE CERTIFIKATER

